



*Bio Instruments S.R.L.*

SENSORS AND SYSTEMS  
FOR MONITORING GROWING PLANTS

# **DE-1z**

*Dendrometer*





## ***Introduction***

The DE-1z Dendrometer is a highly precise incremental LVDT-based sensor for monitoring micro-variations of trunk radius in micron range.

The sensor includes a linear displacement transducer (LVDT) mounted on a special rod with threaded end. When the rod is anchored inside the trunk, the LVDT rod follows movement of the trunk surface. The output signal follows the variation of distance between trunk surface and the anchored end of the rod.

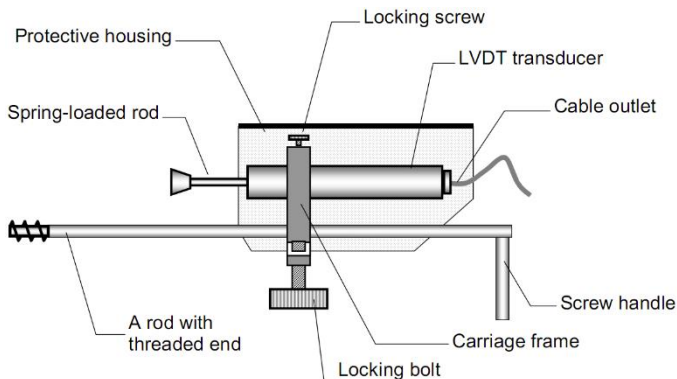

The probe is connected by a standard 2-meter cable to the waterproof box with the signal conditioner inside.

Plant growth and water balance affect diurnal behavior of stem diameter. The growth rate depends on a vegetation stage and environmental conditions. The diurnal variations represent mostly fluctuations of water content in plants. Two diameter-based indices are commonly used for evaluating plant water status: daily contraction amplitude and trend of daily maxima. The DE-1z sensor allows investigating effects of irrigation rate and other environmental factors on water balance and growth of plants.

## ***Installation***

- In trees with rough bark over the cambium, rasp it away and pare down carefully an area of about  $6 L \times 5 W$  cm<sup>2</sup>. In caulis and species with smooth bark, no preparation may be needed.
- Drill the hole with the 3.3 – 3.5 mm bits. It is recommended to drill slowly using a wood drill set to a low torque to prevent excessive tearing of wood fibers along the length of hole. The depth of hole must be 3 cm min. and 9 cm max.
- Free the locking bolt and remove the rod from the carriage frame.

- Carefully screw the rod into the tree. If there is difficulty in insertion, clear the hole carefully with the drill bit.
- Once the rod is implanted, set the sensor on the rod and adjust its position until the butt of spring-loaded rod touches the trunk.
- Readjust the sensor when its readings become close to 0 or 10 mm.

### **Communication**

The DE-1z sensor communicates over the radio 2.4 GHz channel with a network data logging unit. Activation of the sensor and measurement settings are described in the Quick Start Guide of the data logging unit (PTM-50 or PM-11z Phytomonitor or PC Phyto-Logger)

### **Power**

The DE-1z sensor is powered by three AA Alkaline batteries.

### **Readings**

The DE-1z sensor represents the end value made at the end of the measurement time interval.

## ***Customer Support***

If you ever need assistance with your equipment, or if you just have questions or feedback, please e-mail at [support@phyto-sensor.com](mailto:support@phyto-sensor.com). Please include as part of your message your name, address, phone, and fax number along with a description of your problem.

## ***Specifications***

|                                                   |                          |
|---------------------------------------------------|--------------------------|
| Measurement range                                 | 0 to 10 mm               |
| Trunk diameter range                              | Above 6 cm               |
| Resolution                                        | 0.005 mm                 |
| Operating temperature                             | 0 to 50°C                |
| Temperature effect                                | < 0.02% total stroke /°C |
| Protection index                                  | IP 64                    |
| Overall dimensions, mm                            | 90 W × 60 H × 23 D       |
| Carrying rod, mm                                  | 160 L × 4Ø               |
| Threaded end, mm                                  | 10 L × 5 Ø               |
| Cable length between probe and signal conditioner | 2 m                      |



Phyto-Sensor Group

**Bio Instruments S.R.L.**

20 Padurii St., Chisinau MD-2002

REPUBLIC OF MOLDOVA

Tel./Fax: +373-22-550026

[info@phyto-sensor.com](mailto:info@phyto-sensor.com)

[www.phyto-sensor.com](http://www.phyto-sensor.com)